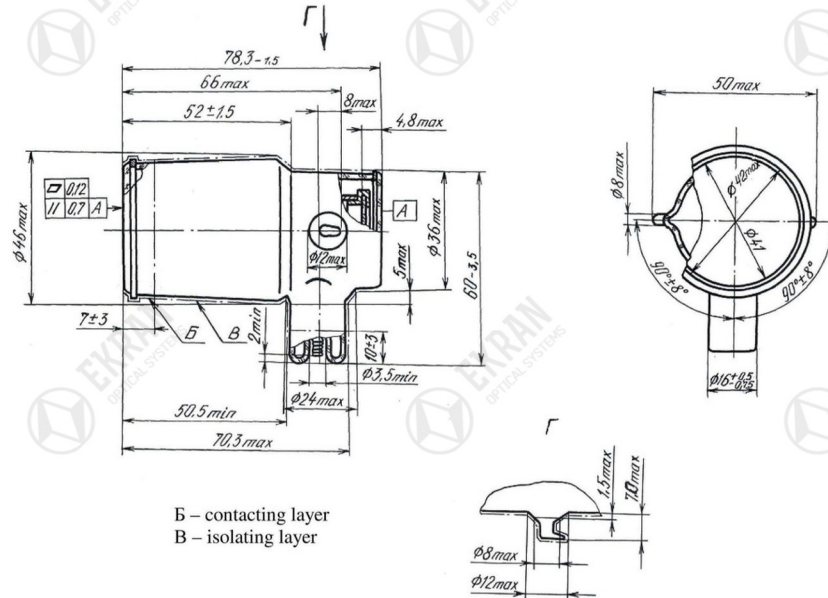

Image intensifier tube V-2

V-2 – single chamber device in glass version, has a two-electrode electrostatic focusing system, multialkaline photocathode S25 in the area of wavelengths 350-900 nm, yellow-green color screen of luminescence.

V-2 is a component element in the night vision devices for the brightness magnification of image at the natural night light and with the using of IR illumination.



Technical specification

Parameter, unit	Values
Photocathode integral sensitivity, mkA/lm, no less	250
Photocathode sensitivity with filter, mkA/lm, no less	70
Resolution at center, lm/mm, no less	35
Operating resolution, lm/mm, no less	28
Image intensifier magnification, rel. u	0,52
Useful photocathode diameter, mm	33,5
Operating voltage, kV	19
MTF, h, no less	1000
Mechanical shock with peak shock acceleration, m/c ² (g)	
- single action	1500 (150)
- reoperable	400 (40)
Operating temperature, °C	-50 ÷ +50
Weight, g, no more	60

Purity of the visual area:

Zone	Form and size of zones on photocathode, mm	The greatest diameter of points, mm			The total area of allowable defects on the screen, mm ²
		Non accounted	Accounted		
			Size	Quantity	
1	Circle Ø 16,75	0,05	0,15	3	0,072
2	Ring Ø 16,75-26,8	0,10	0,25	4	0,238
3	Ring Ø 26,8-33,5	0,15	0,50	2	0,475



EKRAN
OPTICAL SYSTEMS

JSC «Ekran - optical systems»
630047 Russia, Novosibirsk, Dargomyzhskogo 8a

F: +7(383)325-17-58 M: info@ekran-os.ru www.ekran-os.ru