



IIT '0' Gen



EKTRAN
OPTICAL SYSTEMS



Image intensifier tube V-8A1

V-8A1 – single chamber device in glass version, has a two-electrode electrostatic focusing system, multialkaline photocathode in the area of wavelengths 350-900 nm, yellow-green color screen of luminescence.

V-8A1 is a component element in the night vision devices for the brightness magnification and converting an infrared image into a visible with the using of IR illumination.

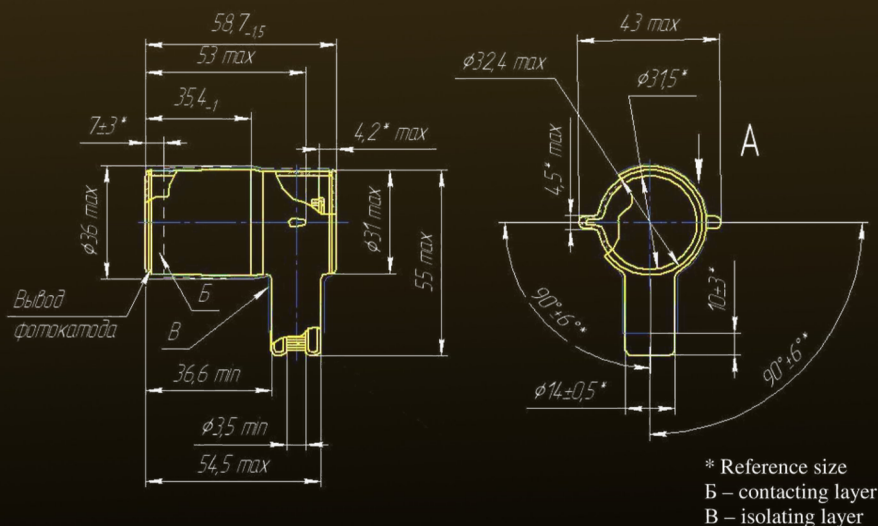

Technical specification

Parameter, unit	Values
Photocathode sensitivity with filter KC-27, mkA/lm, no less	140
Resolution, lm/mm, no less	40
Operating resolution, lm/mm, at 0,001 lk, no less	28
Image intensifier magnification, rel. u	0,47
Useful photocathode diameter, mm	24
Operating voltage, kV	19
MTF, h, no less	1000
Mechanical shock with peak shock acceleration, m/c ² (g)	
- single action	4000 (400)
- reoperable	2500 (250)
Operating temperature, °C	-40 ÷ +40

Purity of the visual area (allowable dimensions of stationary dark spots):

Zone	Form and size of zones on photocathode, mm	The greatest diameter of points, mm			The total area of allowable defects on the screen, mm ²
		Non accounted	Accounted		
			Size	Quantity	
1	Circle Ø 12,0	0,047	0,235	1	0,0433
2	Ring Ø 12,0-19,2	0,073	0,294	2	0,1357
3	Ring Ø 19,2-24,0	0,235	0,588	1	0,2714