



IIT '0' Gen



EKCRAN
OPTICAL SYSTEMS



Image intensifier tube EP-US-D

EP33-US-D— single chamber device in glass version, has a two-electrode electrostatic focusing system, multialkaline photocathode S25 in the area of wavelengths 350-900 nm, yellow-green color screen of luminescence.

EP33-US-D is a component element in the night vision devices for the brightness magnification of image at the natural night light.

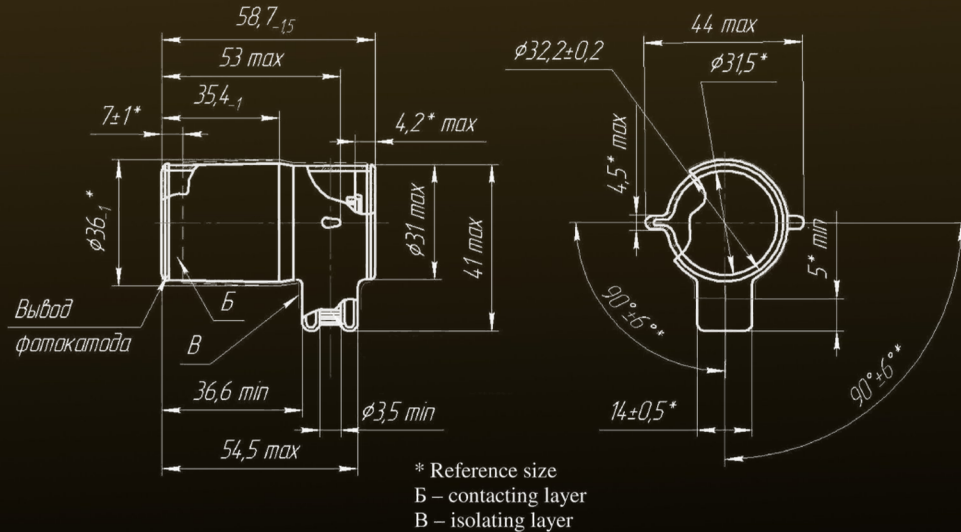

Technical specification

Parameter, unit	Values
Photocathode integral sensitivity, mkA/lm, no less	200
Photocathode sensitivity with filter, mkA/lm, no less	70
Resolution, lm/mm, no less	30
Operating resolution, lm/mm, no less	24
Image intensifier magnification, rel. u	0,47
Useful photocathode diameter, mm	24
Eccentricity, mm, no more	0,5
Operating voltage, kV	18
MTF, h, no less	1000
Mechanical shock with peak shock acceleration, m/c ² (g)	
- single action	1500 (150)
- reoperable	150 (15)
Operating temperature, °C	-40 ÷ +40

Purity of the visual area (allowable dimensions of stationary dark spots visible on the screen):

Zone	Form and size of zones on photocathode, mm	The greatest diameter of points, mm			The total area of allowable defects on the screen, mm ²
		Non accounted	Accounted		
			Size	Quantity	
1	Circle Ø 12,0	0,047	0,235	1	0,0433
2	Ring Ø 12,0-19,2	0,073	0,294	2	0,1357
3	Ring Ø 19,2-24,0	Non specified			



JSC «Ekran - optical systems»
630047 Russia, Novosibirsk, Dargomyzhskogo 8a

F: +7(383)325-17-58 M: info@ekran-os.ru www.ekran-os.ru